

# On Street Dining Guidelines and Specifications



# Table of Contents

<b>1</b>	<b>Introduction</b>	<b>3</b>
<b>2</b>	<b>Dining Furniture</b>	<b>4</b>
<b>3</b>	<b>Screen Fence</b>	<b>5</b>
<b>4</b>	<b>Dining Area Surface</b>	<b>7</b>
<b>5</b>	<b>Bollards</b>	<b>7</b>
<b>6</b>	<b>Shade Structures</b>	<b>8</b>
<b>7</b>	<b>Maintenance &amp; Management of the on street dining area</b>	<b>9</b>
<b>8</b>	<b>Areas not suitable for on street dining</b>	<b>9</b>
<b>9</b>	<b>Application Process</b>	<b>11</b>
<b>10</b>	<b>Construction of Works</b>	<b>12</b>
<b>11</b>	<b>Annual Licence</b>	<b>12</b>
<b>12</b>	<b>Termination</b>	<b>12</b>

# 1. Introduction

## 1.1 Purpose of the Guidelines

These technical guidelines have been developed to maintain the balance between pedestrian safety and access and utilising the public footpath for On Street Dining. It provides simple urban design guidelines and acceptable solutions for On Street Dining activities.

These Guidelines must be read in conjunction with Council's 'On Street Trading Activities Policy' (18-PI-011). A copy is available by contacting Council's Customer Service Centre or accessing Council's web site [www.launceston.tas.gov.au](http://www.launceston.tas.gov.au).

## 1.2 Guideline application areas

These On Street Dining Guidelines apply to all public roads and streets in the entire municipality of Launceston.

## 1.3 Definitions

(Also to be read with definitions in 'On Street Trading Activities Policy')

**'authorised officer'** means a person employed by the Council in the position of Director Infrastructure Services, Environmental Services Officer or Environmental Health Officer.

**'Council'** means the City of Launceston.

**'licence'** means a pavement encroachment licence issued by the Council in accordance to these Guidelines.

**'pedestrian areas'** include malls, avenues and any other public road reserve / footpaths defined by the Director Infrastructure Services.

**'street dining'** means the consumption of food and or beverages by seated customers in an area on a highway external to a shop or restaurant licensed to serve food and managed by that shop or restaurant.

**'waste bins'** means a receptacle provided for the disposal of single service food containers and implements for use by patrons using the licensed area.

## **2. Dining Furniture**

### **2.1 Dining Furniture**

Includes tables, chairs, screen fences, umbrellas, portable heaters and the like.

### **2.2 Design of Dining Furniture**

The design of dining furniture shall:

- All legs or points of contact must be designed to prevent damage to footpath paving
- Where kerbside parking occurs a screen fence must be installed.
- Waste bins shall be required when shown on the approved plan
- Advertising logos or signs are not allowed on any furniture however logos may be permitted on umbrellas and screen fence panels

### **2.3 Placement of Dining Furniture**

The dining furniture shall be placed so that:

- It must be retained within the area approved in the licence issue by the Council.
- The clearance between any part of the dining furniture and the property line (i.e. shopfront).
  - 2500mm minimum - Brisbane Street (between St John Street and George Street); and the Brisbane Street Mall.
  - 2000mm minimum - other CBD being Charles, St John and George Streets (between York and Paterson Streets); York and Paterson Streets (between Charles and George Streets); and the Quadrant Mall.
  - 1500mm minimum elsewhere.
  - or any greater clearance as specified in the licence.

The permit holder is responsible for maintaining the required clearances at all times.

- No furniture is to be placed within 1 metre of any parking meter or other street furniture or street tree.

- On street dining is not permitted adjacent to loading zones, bus stops, taxi ranks or road crossing points.
- Diners are at least 600mm clear of any bollard (erected as required by Section 4).

## **2.4 General**

- The licensee must maintain dining furniture in a clean condition and comply with the requirements of the Environmental Services Department.
- The dining furniture shall remain the property of the licensee.
- There shall not be any foundation nor connection point within the footpath. Dining furniture shall be non-fixed.
- No other signage or Front of Shop Module (FoSM) is permitted with the On Street Dining licence.

## **2.5 All furniture must be removed at the end of day trading by the licence holder.**

# **3. Screen Fence**

**3.1** Screen fencing may be free standing or if used in conjunction with fixed bollards the fencing may fit within 25mm wide cleats welded or fixed to the bollards provided there are no shape edges or otherwise a danger to pedestrians.

## **3.2 Screen Fencing Must Be:**

- used if the on street dining area is adjacent to kerbside parking
- along the same alignments as any existing bollards
- used between separately licensed on street dining areas
- removed outside of business hours
- no closer than 550mm to the face of kerb to allow for access to parked cars

**3.3** The screen fencing shall be owned by the On-Street Dining Operator and the fencing must comply with the diagrams below:

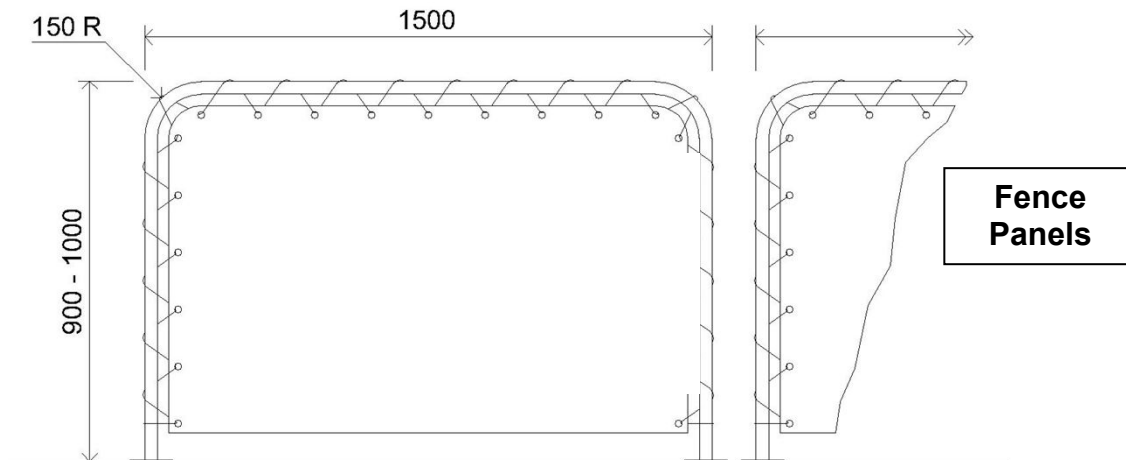
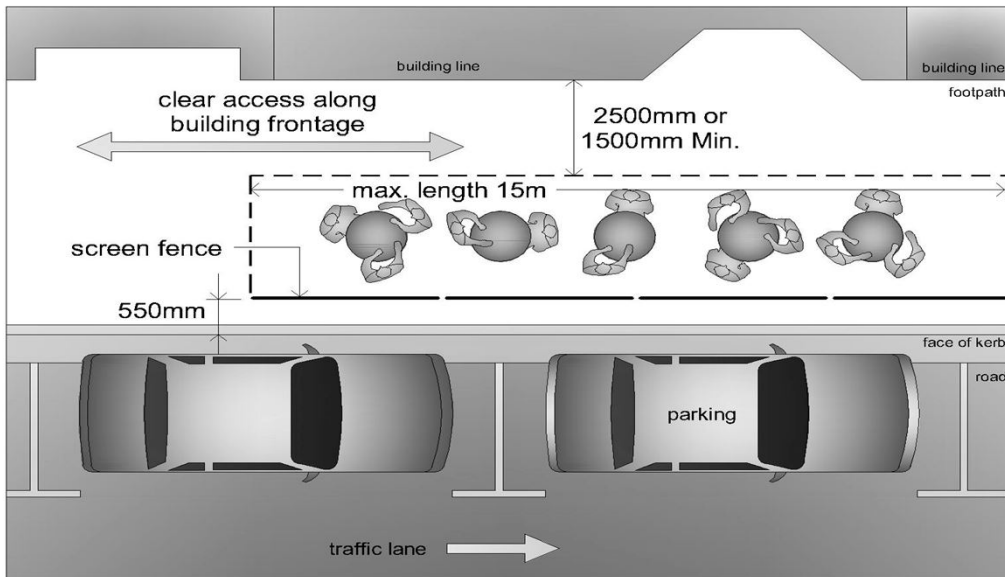

**3.4** The On Street Dining Operator shall monitor the dining area frequently to ensure that screen fences are not a hazard to pedestrians or motorists.

## 4. Dining Area Surface

- 4.1 Generally on-street dining will not be permitted on asphalt or sprayed sealed surfaces due to the imprints caused by dining furniture.
- 4.2 Conditions will be imposed to reconstruct the pavement to provide concrete, large format or brick pavers. The applicant shall be responsible for all costs (including any design plans if considered necessary) associated with the construction.

## 5. Bollards

- 5.1 Bollards are used to improve the safety of patrons dining near traffic lanes. They **must** be used when the dining area is directly adjacent to traffic lanes - including clear lanes and turning lanes (i.e. where there is no on-street parking).
- 5.2 Bollards must:
- be spaced to not exceed 1500mm. If specified in the licence issued by the Council, the gap may be reduced to 1200mm in situations to protect against on-coming traffic and
  - not be closer than 300mm from the face of kerb. Diners must be at least 600mm from any bollards.
- 5.3 The supply and construction of the bollards shall be the responsibility and at the expense of the lessee, and shall:
- comply with the Council's Information Sheet 'Bollards' - 27-Rf-017. (However in critical situations the bollard type and construction may be required to comply with the Australian Standard for Crash testing).
  - be constructed, and approved by the Council's Authorised Officer, before the use of the dining area and
  - become the property of the Council.

*Refer diagram next page.*

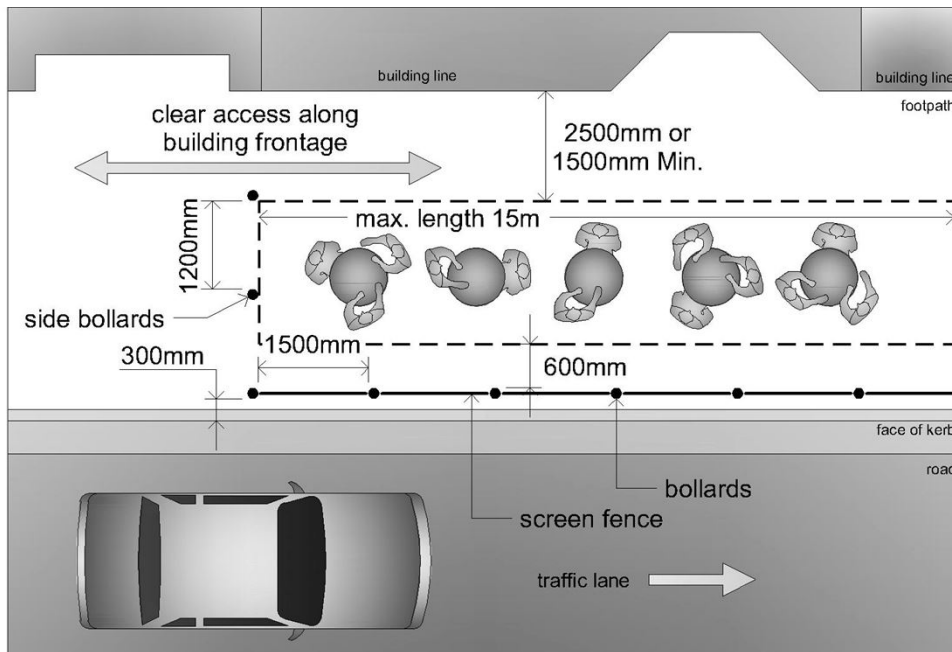

## 6. Shade Structures

**6.1** Shade Structures include sunscreens, free standing awnings, fixed umbrellas and the like.

**6.2** Design and placement of shade structures:

- must have a minimum height above footpath level of 2.4 metres
- edge of awning must be set back at least 450mm from the face of kerb
- footings must be set back at least 550mm from the face of kerb
- footings to be located clear of underground services and shall be owned by the Council

**6.3** Umbrellas, awnings etc must be removed or lowered if weather renders them potentially unsafe.



## **7. Maintenance and Management of the On Street Dining Area**

- 7.1** The Licensee must maintain the area where the licence applies and the area adjacent to it in a clean and sanitary manner. Includes: emptying waste bins, washing pavements on a daily basis, and immediately cleaning and washing away any liquid, food, debris, broken glass, cigarette butts or waste from the area.
- 7.2** A licensee must not use existing street rubbish bins for the disposal of table waste.
- 7.3** Any dining furniture (including tables, chairs, screen fences, umbrellas, portable heaters and the like) shall be removed or re-positioned if they are or likely to be a danger to pedestrians or traffic.
- 7.4** All licensed On-Street Dining areas will be designated smoke-free zones as of 1 January 2011. It is the responsibility of the licensee to ensure that all customers comply with this requirement.

## **8. Areas not suitable for On Street Dining**

- 8.1** On Street Dining will be prohibited:
- Where it blocks sight distance on street corners or where significant driveways enter road. A significant driveway is a driveway that is estimated to carry 40 or more traffic movements per day
  - Where it blocks sight distance to pedestrian crossing points
  - Adjacent to bus stops, loading zones or taxi ranks
  - Where there are significant trip hazards due to drainage channels, steps or changes in levels
  - Where it reduces pedestrian paths to less than specified in Section 2.3.
  - Where the Environmental Services Department or Planning Department have not allowed modification of the building to cater for the On Street Dining.
  - On asphalt pavements due to imprints caused by dining furniture.

- Where the registered food business does not have good visual contact or good ability to adequately monitor the potential on-street dining area.
- Where the business is unable to comply with the Building Code of Australia's toilet provisions
- Within 20m on the approach to traffic light intersections
- Within 10m on the approach to any other traffic intersection
- Within 5m on the departure of any intersection

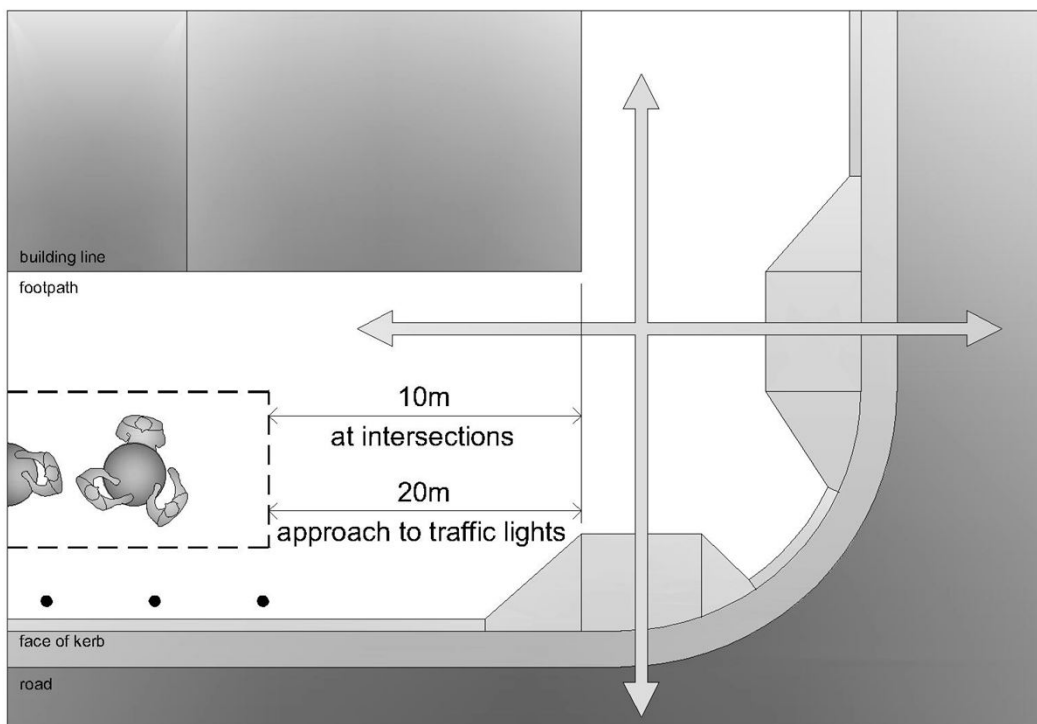

**8.2** The business must be conducted from within the business premises and not under any circumstance be conducted from a hutch opening onto the footpath.

## 9. Application Process

9.1 Once you consider you comply with these guidelines, you will need to complete an "Application for On Street Dining" form.

The form can be obtained:

In person: Customer Service Centre  
St John Street, Launceston

By phone: 6323 3000

Internet: [www.launceston.tas.gov.au](http://www.launceston.tas.gov.au)

9.2 A minor intrusion of a dining area in front of an adjacent premise if approved by both the occupier and the owner may be approved by the Manager Environmental Services.

9.3 Conditions of granting a licence are that the applicant's premises have kitchens licensed by the Environmental Services Department under the *Food Act 2003*.

9.4 A licence will be issued if the application is approved and upon receipt of:

- The annual licence fee (determined on the area of the On Street Dining). An additional fee (equivalent to the loss of revenue) shall apply if the application includes the removal of street parking.
- Proof of insurances. An applicant must have public and products liability insurance that covers the area designated for on street dining before the applicant is issued with a licence. The insurance cover is to be for the sum of \$10 million and be in a form acceptable to Council. A licence holder must produce a Certificate of Currency of the insurance which provides a clear statement that acknowledges the insurer is aware of the extension to the business to include the on street dining area.

## 10. Construction of Works

- 10.1** If the approved application includes the construction of fixed works - such as bollards, insitu foundations, footpath pavement or kerb extensions, then the licensee must reach an agreement with Council for the construction of road works within a public road to improve a streetscape for on street dining and the works will be carried out by a Council registered Contractor to work in the road reserve. The Council may require plans to be prepared prior to construction.
- 10.2** All works will be the responsibility and at the expense of the licensee.

## 11. Annual Licence

The licensee shall submit an application and fee annually to re-issue the licence. A renewal notice and invoice is issued by the Environmental Services Department after 31 December each year.

## 12. Termination

- 12.1** The Council may terminate the license at any time if the licensee:
- fails to maintain their premises in accordance with these guidelines and any condition attached to the licence.
  - fails to comply with a notice issued by an authorised officer to bring the premises into compliance.
- 12.2** Termination of the license can only be undertaken by the Manager Environmental Services.

**PURPOSE**

<< A broad statement about what the flowchart, form or checklist sets out to achieve. >>

**SCOPE**

<< To whom, what and where the flowchart, form or checklist is applied. >>

- << You can use subheadings and dot points, as appropriate. >>

**RELATED POLICIES & PROCEDURES**

<< List the procedure this flowchart, form or checklist underpins and any related forms etc. A change in one document may require review of another.>>

- << You can use subheadings and dot points, as appropriate. >>

**DOCUMENT INFORMATION**

<b>Reference number</b>	18/Rfx-033
<b>Version</b>	13/10/2016
<b>Review</b>	
<b>Key function</b>	Land Use & Development
<b>System</b>	
<b>Document type</b>	High Level or Detail Procedure
<b>Responsible Directorate</b>	Infrastructure
<b>Approved by</b>	Manager Infrastructure
<b>Action Officer</b>	Harry Galea
<b>Text search key words</b>	On street dining guidelines specifications

<b>To be communicated to</b> (To be identified by Approver) (Insert ✓ in relevant row)		Department/Area only
		Directorate via Director and Managers
		Specific Areas:
	✓	• Organisation-wide
	✓	Website
		Intranet (via a link)

<b>Hard copy distribution</b>	N/A
-------------------------------	-----